

22 MHz Video Amplifier for Large Jumbo Picture Tubes

ETV/AN95008

**22 MHz Video Amplifier for
Large Jumbo Picture Tubes**

**Application Note
ETV/AN95008**

Abstract

This report is the description of a video amplifier board that is intended for the display of high resolution TV and VGA images on the Philips large screen picture tubes using the RGB video processor TDA4780 and the integrated video output amplifier TDA6120. The RGB bandwidth of the total amplifier circuit is 22 MHz. The TDA4780 video controller is I²C controlled, offers automatic cut-off control and special features like blue stretching and gamma control.

Note: This report is based upon preliminary data sheets and build with test samples of the TDA6120. Modifications after the date of issue of this report are possible.



Purchase of Philips I²C components conveys a license under the I²C patent to use the components in the I²C system, provided the system conforms to the I²C specifications defined by Philips.

© Philips Electronics N.V. 1996

All rights are reserved. Reproduction in whole or in part is prohibited without the prior written consent of the copyright owner.

The information presented in this document does not form part of any quotation or contract, is believed to be accurate and reliable and may be changed without notice. No liability will be accepted by the publisher for any consequence of its use. Publication thereof does not convey nor imply any license under patent- or other industrial or intellectual property rights.

APPLICATION NOTE

**22 MHz Video Amplifier for
Large Jumbo Picture Tubes**

ETV/AN95008

Author(s):

J.J. Hekker

**Product Concept & Application Laboratory Eindhoven,
The Netherlands.**

Keywords

Video Amplifier
High Resolution
Blue Stretch
Gamma Control
Cut-off Control

Date: 16th March, 1996

Pages: 35

**22 MHz Video Amplifier for
Large Jumbo Picture Tubes**

**Application Note
ETV/AN95008**

Summary

This report describes the design of a video amplifier circuit that is intended to drive Philips picture tubes in the PCALE large screen HR Monitor. The total video amplifier circuit consists of the TDA4780 RGB video processor and a video output stage using three TDA6120 integrated output amplifiers.

The (-3dB) RGB video bandwidth of the total amplifier circuit is 22 MHz .

Note: *The video amplifier circuit described in this report is built and tested with preliminary samples of the TDA6120 output amplifier. For this reason this report is considered "classified".*

**22 MHz Video Amplifier for
Large Jumbo Picture Tubes**

**Application Note
ETV/AN95008**

CONTENTS

1. INTRODUCTION.	7
2. VIDEO AMPLIFIER DESIGN.	8
2.1 The Video Pre-Amplifier.	9
2.1.1 The TDA4780 Video Pre-Amplifier Input Circuit.	9
2.1.2 Sandcastle input.	9
2.1.3 Beam Current Limiting (BCL) and TDA6120 Thermal Protection.	10
2.2 The Video Output Amplifier.	11
2.2.1 Power Dissipation of the TDA6120 and Heatsink Design.	12
- Calculating the power dissipation (static + dynamic) of the TDA6120:	12
- Measuring the Power Dissipation of the TDA6120 in practise.	13
2.3 The Interface between TDA4780 and TDA6120.	15
3. POWER SUPPLY.	15
3.1 Performance of the Video Amplifier Board.	16
4. VIDEO AMPLIFIER BOARD SCHEMATIC DIAGRAMS, LAYOUT AND PARTS LISTS.	17
4.1 Picture Tube Drive.	17
4.2 Video Amplifier Board Design.	17
4.3 Parts List.	26
4.4 Heatsink used on the Video Amplifier Board.	30
5. ACKNOWLEDGMENT.	31
6. REFERENCES.	31
APPENDIX 1 SPECIFICATION AND PINNING OF THE INTEGRATED CIRCUITS.	32
APPENDIX 2 SPECIFICATION AND TIMING OF ACCEPTED VIDEO DISPLAY MODES.	34

22 MHz Video Amplifier for Large Jumbo Picture Tubes

Application Note
ETV/AN95008

LIST OF FIGURES

Fig. 1 Illustration of cut-off limits and power supply.	8
Fig. 2 Video and Sandcastle inputs of the TDA4780	9
Fig. 3 Beam Current Limiting TDA4780 and Thermal Protection TDA6120	10
Fig. 4 Circuit design TDA6120.	11
Fig. 5 Combining the TDA4780 and TDA6120.	15
Fig. 6 Power supply for the video board.	15
Fig. 7 Video Pre-Amplifier Input Signal	16
Fig. 8 Video Pre-Amplifier (TDA4780) Output	16
Fig. 9 Video Output Amplifier (TDA6120) Signal	16
Fig. 10 Video Output Amplifier (TDA6120) Signal	16
Fig. 11 Circuit and Connections of Picture Tube	17
Fig. 12 Video Amplifier Component Side (Ground Plane and Numbers)	18
Fig. 13 Video amplifier with TDA4780 and TDA6120 schematic diagram.	19
Fig. 14 Video amplifier component placement (numbers).	20
Fig. 15 Video amplifier component placement (values)	21
Fig. 16 Video amplifier SMD placement (numbers)	22
Fig. 17 Video amplifier SMD placement (values)	23
Fig. 18 TDA4780 SMD placement (Numbers) Enlarged View.	24
Fig. 19 TDA4780 SMD Placement (Values) Enlarged View.	24
Fig. 20 TDA6120 SMD Placement (Numbers) Enlarged View.	25
Fig. 21 TDA6120 SMD Placement (Values) Enlarged View.	25
Fig. 22 Heatsink for the TDA6120Q	30

LIST OF TABLES

TABLE 1 Pin Description of the TDA4780 Video Processor.	32
TABLE 2 Pin Description of the TDA6120Q Video Output Amplifier (Preliminary data).	33
TABLE 3 Performance Demands of an Asymmetrical Video Amplifier.	34

22 MHz Video Amplifier for Large Jumbo Picture Tubes

Application Note ETV/AN95008

1. INTRODUCTION.

This report describes the video amplifier circuitry incorporating combination of the RGB video processor TDA4780¹ and the TDA6120² integrated video output amplifier. It contains the circuit diagram, PCB layout and parts list.

The amplifier board is designed to drive TV tubes in a high demanding market of HR monitors*. This means that the required bandwidth of the video amplifier has to meet the following standards:

VGA, SVGA, XGA, MUSE and other High Resolution sources.

A split is made for two different video boards.

- One video amplifier board design for typical TV application, using the combination TDA4780 (monolithic RGB processor) and TDA6120. This combination has a total RGB bandwidth of 22 MHz and is suitable for TV, MUSE, VGA (SVGA and XGA with limited performance) and HDMAC images. It features automatic cut-off control, gamma correction and blue stretch.
- The other video amplifier board is designed for monitor applications, using the combination TDA4882³ video pre-amplifier and TDA6120. This combination has a total RGB bandwidth of 30 - 60 MHz (depending on cathode swing) and is suitable for VGA, SVGA and XGA images.

In this report the combination of the TDA4780 and the TDA6120 for TV/VGA applications is described. The video amplifier board with the combination of the TDA4882 and the TDA6120 is described separately in report ETV/AN95007⁴.

Erratum: With the present bandwidth limiting capacitors C40, C41 and C42 the rise cq. fall time of the input signals is limited to 33 ns. For a better video bandwidth performance, the capacitors C40, C41 and C42 should be reduced in value from 150 pF to 56 pF (limiting the rise cq. fall time to 18 ns). When this alteration is made, the speed-up capacitors C101, C201 and C301 should be reduced in value from 22 pF to 15 pF.

* HR = High Resolution.

22 MHz Video Amplifier for Large Jumbo Picture Tubes

Application Note ETV/AN95008

2. VIDEO AMPLIFIER DESIGN.

For the total video board the following design functions and parameters are realised:

(For the specification of the TDA6120, the relevant data is given in appendix 1 table 2, this data is based on preliminary data sheets and test samples of the TDA6120)

- Two RGB Video inputs 0.7 V_{pp} signal amplitude (in 75 Ω)
- Luminance input 0.45 V_{pp} (or 1.43 V_{pp}, can be selected through I²C)
- Colour difference input
 - (R-Y) 1.05 V_{pp}
 - (B-Y) 1.33 V_{pp}
- Contrast control
- Brightness control
- RGB Black level control
- Automatic cut-off control
- RGB Gain control
- I²C control
- Video Output Stages supply voltage of 200 Volt
- Highest cut-off level 160 Volt (Specification for Philips large screen picture tubes)
- Maximum output swing 150 Volt (120 Volt video drive and 30 Volt cut-off adjustment range)
- Bandwidth minimum 22 MHz / 125 Volt (limited by RGB bandwidth of the TDA4780)

The video output stage ranges are illustrated in Fig. 1.

- The connector pinning is compatible with the other board designs for the HR monitor series.

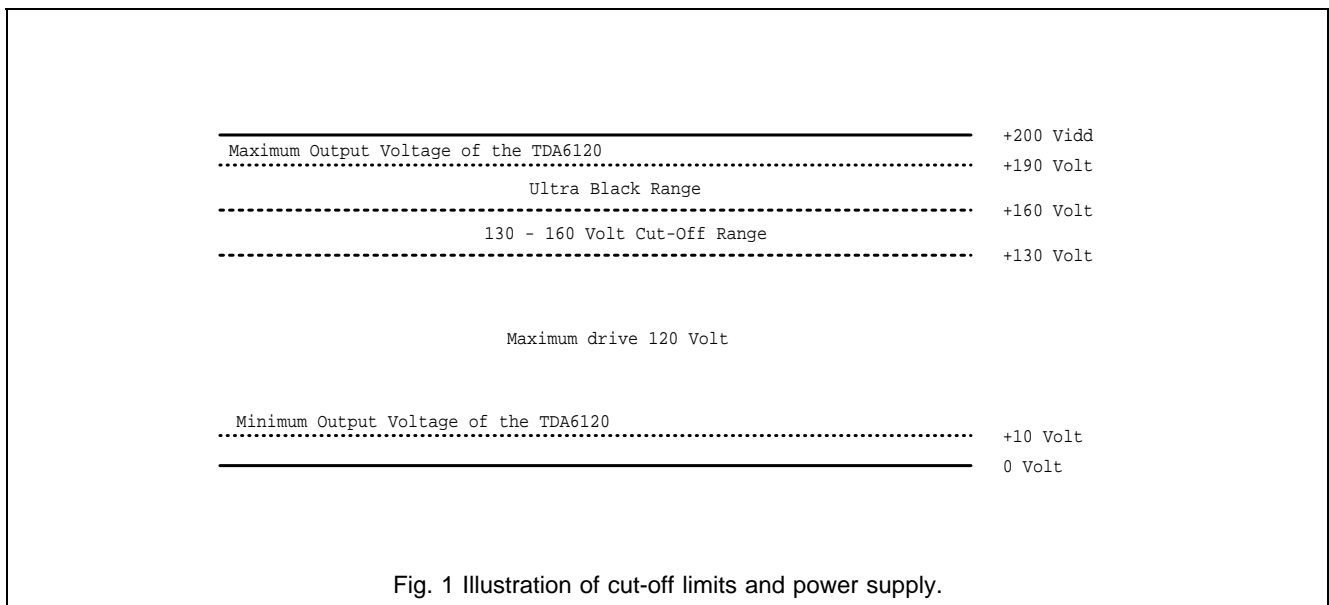

22 MHz Video Amplifier for Large Jumbo Picture Tubes

Application Note ETV/AN95008

2.1 The Video Pre-Amplifier.

The pinning of the TDA4780 is given in appendix 1 table 1. The supply voltage is 8 Volt.

2.1.1 The TDA4780 Video Pre-Amplifier Input Circuit.

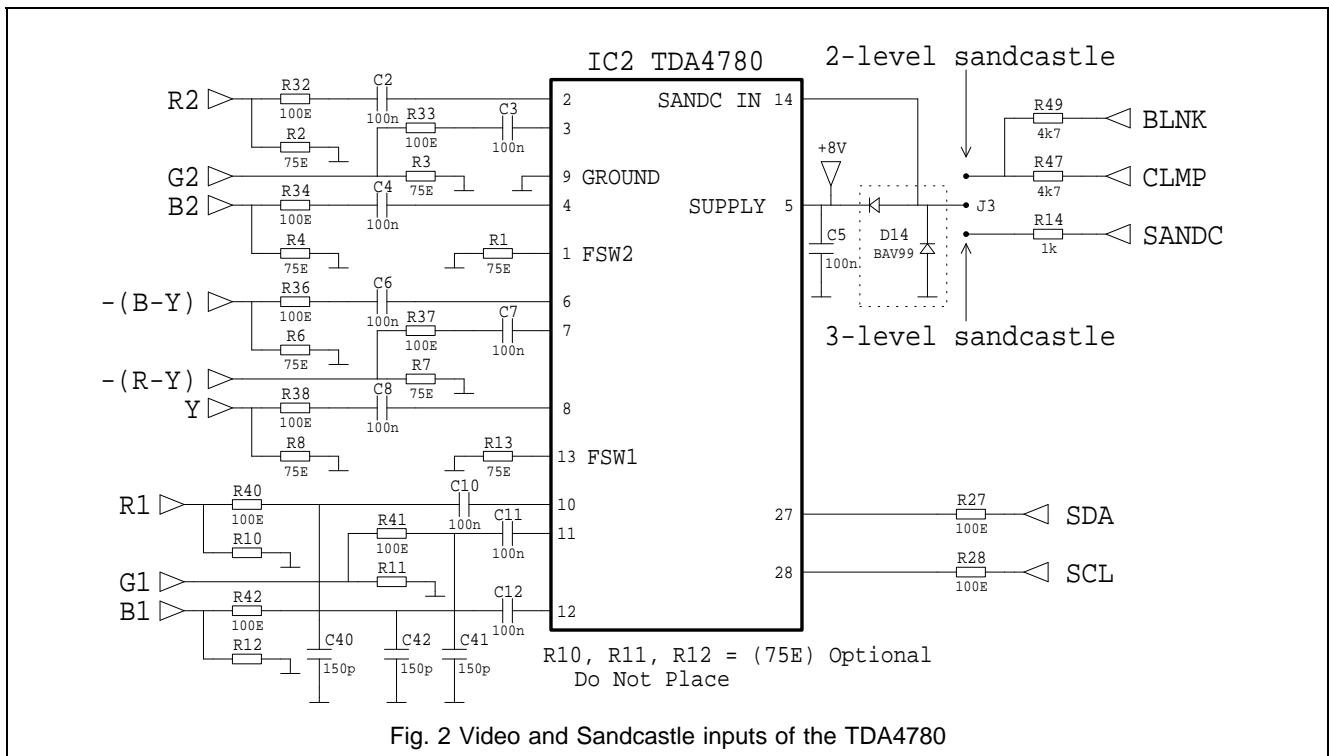

All the video input signals are terminated with 75 Ω to ground, see Fig. 2 (do not place R10, R11 and R12, these resistors are usually placed at another position inside the set e.g. at the BNC input connectors, and therefore not at the video board). The video signals are AC coupled (100 nF SMD) to the inputs of the TDA4780. Capacitors C40, C41 and C42 are added to limit the bandwidth of the input signal. This allows for a more optimal design of the speed-up network (R•01, R•03 and C•01 at the input of the TDA6120) and the SVM circuit (for this circuit see o.a. report ETV/AN93014⁵).

2.1.2 Sandcastle input.

The TDA4780 must have a two- or three-level (selected through I²C) sandcastle signal for operation. For use in HR monitors the sandcastle generated on the deflection board is not suitable, because of too much delay. Therefore the 5 Volt blanking and clamping pulses are added with two 4k7 Ω resistors to form a two level sandcastle. When the HR monitors are used for TV images the standard 3 level sandcastle can be used. The sandcastle (2- or 3-level) can be selected with jumper J3.

Note: *With the two-level sandcastle both blanking and clamping pulse must be present for operation. When no clamping is present, no blanking or constant blanking is required.*

22 MHz Video Amplifier for Large Jumbo Picture Tubes

Application Note ETV/AN95008

2.1.3 Beam Current Limiting (BCL) and TDA6120 Thermal Protection.

The beam current information is measured at the foot of the EHT winding (see also ETV/AN95006⁶). This information is offered through a diode and a two resistors to pin 15 (average beam current limiting input) of the TDA4780. A fast acting, slow restoring beam current limiting system is made by including a 100 μF capacitor (C26). The initial BCL level is set to approximately 4.2 Volt with resistors R14 and R16. The BCL information is clipped with a 6.8 Volt zener to prevent overdrive on the TDA4780 input.

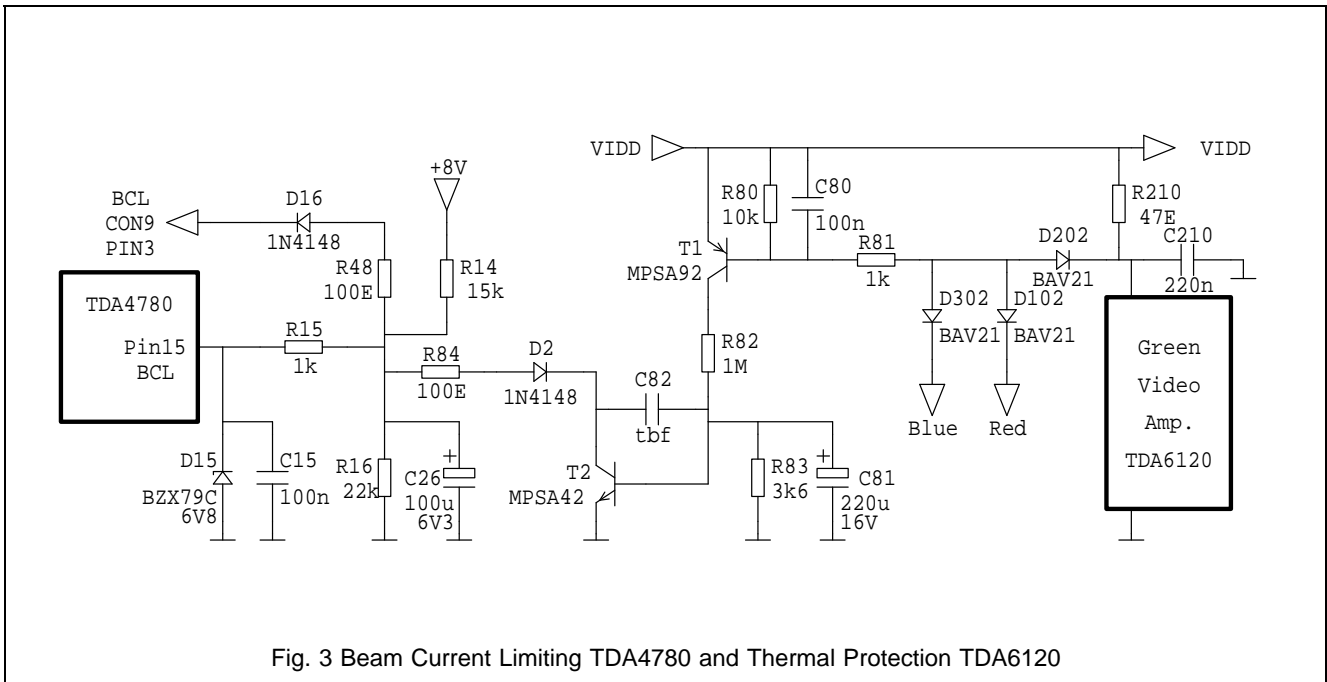

Fig. 3 Beam Current Limiting TDA4780 and Thermal Protection TDA6120

The network with transistors T1 and T2 is added for thermal protection of the TDA6120.

The current through resistor R•10* is a good representation of the total dissipation ($P_{tot} = P_{dyn} + P_{stat}$) of the TDA6120. This information can be used by the thermal protection circuit, as shown in the network around T1 and T2, to pull down the contrast level when the expected dissipation exceeds a certain level. With the resistor values indicated in Fig. 3 (47 Ω) the voltage over resistors R•10 is limited to 1.2 Volt (by limiting the current through R•10 to approximately 30 mA). This results in a ΔT (with the used heatsink of Fig. 22) of approximately 27 °C.

The capacitor C81 (C82 is optional) is used to include a time constant to prevent visible background modulation and loop instability.

* R•10 means this resistor is numbered as R110, R210 or R310 for respectively the Red, Green or Blue output stage.

22 MHz Video Amplifier for Large Jumbo Picture Tubes

Application Note ETV/AN95008

2.2 The Video Output Amplifier.

The video output stage is built around the TDA6120 integrated video output amplifier.

The TDA6120 has a small signal bandwidth of 60 MHz and a large signal bandwidth of 30 MHz. The peripheral circuit around the TDA6120 is shown in Fig. 4. The pinning is given in appendix 1 table 2.

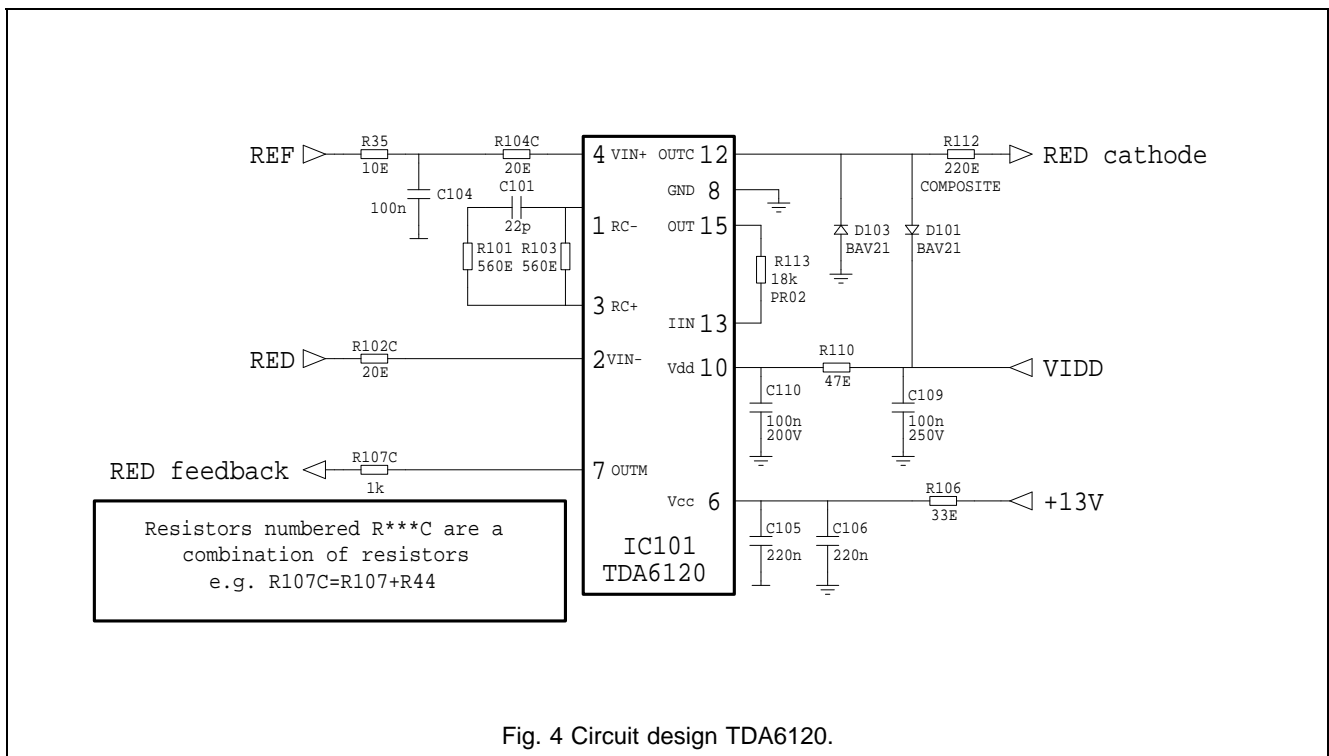

The main features of the TDA6120 are (data based on preliminary data sheets and test samples of the TDA6120):

- Large signal bandwidth of 30 MHz at 125 V_{pp}
- Small signal bandwidth of 60 MHz at 60 V_{pp}
- Rise/fall time of 12.5 ns for 125 V_{pp}
- Slew rate of 10 V/ns
- Static power dissipation of 3.5W at 200 Volt supply (each device)
- Bandwidth independent of voltage gain
- Maximum overall voltage gain over 46dB
- Differential voltage input
- Fast cathode current measurement output for dark-current control loop.
- High power supply rejection ratio.

The reference of the TDA6120 (VIN+) is 3.9 Volt, see also paragraph 2.3. The output voltage of the TDA6120 is fixed with a feedback resistor R•13. With the value of resistor R•13 = 18 kΩ, an ultra black level of 180 Volt and no differential input voltage, the output voltage of the TDA6120 is 90 Volt.

22 MHz Video Amplifier for Large Jumbo Picture Tubes

Application Note ETV/AN95008

2.2.1 Power Dissipation of the TDA6120 and Heatsink Design.

In the circuit described in this report, the bandwidth of the video path is limited by the video pre-amplifier, the TDA4780. The -3dB bandwidth of this IC is 22 MHz. In practise this means that the maximum worst case condition will be reached around 22 MHz with an amplitude of 100 Volt (The amplitude is limited by a combination of bandwidth, beam current limiting and voltage output of the TDA4780).

In the first part of this paragraph the theory on calculating the dissipation and temperature rise of the video amplifiers at normal conditions (pixel on/off at 22 MHz at 100 Volt cathode drive voltage, amplitude is limited by the beam current limiting circuit) is explained.

In the second part the more practical approach of driving the TDA6120 to its worst case condition (a combination of maximum output times maximum frequency) is used.

Note: *These worst case conditions are only reached with the thermal protection circuit disabled.*

Calculating the power dissipation (static + dynamic) of the TDA6120:

The static dissipation (P_{stat}) of the TDA6120 (datasheet) is due to supply currents and currents in the feedback network and CRT, and can be calculated with equation (1):

$$P_{stat} = V_{idd} * I_{dd} + V_{cc} * I_{cc} \quad (1)$$

and:	$V_{idd} = 200 \text{ V}$	$I_{dd} = 14.7 \text{ mA}$	(from preliminary data)
	$V_{cc} = 15 \text{ V}$	$I_{cc} = 37 \text{ mA}$	(from preliminary data)

is $P_{stat} = 3.5 \text{ Watt}$

The dynamic dissipation (P_{dyn}) of the TDA6120 can be calculated with equation (2):

$$P_{dyn} = V_{idd} * (C_l + C_f + C_{int}) * f * V_{o,pp} * b \quad (2)$$

and:	C_l	= load capacitance (= $C_{tube} + C_{socket} + C_{sparkgap} + 2 \times C_{diode} + 2 \times C_{flashR} + C_{traces}$) = $4 + 1 + 0.5 + 1.5 + 3 + 0.75 \approx 11 \text{ pF}$
	C_f	= feedback capacitance ($\approx 1.5 \text{ pF}$)
	C_{int}	= effective internal load capacitance ($\approx 7 \text{ pF}$, estimate)
	f	= frequency
	$V_{o,pp}$	= peak to peak output voltage ($\approx 100 \text{ Volt}$ at 22 MHz normal operation)
	b	= non blanking duty-cycle (≈ 0.8)

The capacitances indicated in above formula are an educated guess of the capacitance present in the board design and the video end amplifier.

then $P_{dyn} = 6.9 \text{ Watt}$

22 MHz Video Amplifier for Large Jumbo Picture Tubes

Application Note ETV/AN95008

Thermal parameters of the TDA6120 and heatsink:

$R_{th,j-mb}$	=	2.0 K/W	(Thermal resistance junction to mounting base)
$R_{th,mb-hs}$	=	0.5 K/W	(Thermal resistance mounting base to heatsink)
$T_{j,max}$	=	150 °C (473 K)	(Maximum junction temperature)
$T_{hs,max}$	=	105 °C (368 K)*	(Maximum temperature heatsink)
$T_{amb,tv}$	=	65 °C (338 K)	

With the total dissipation of 10.4 Watt under normal operating conditions and the thermal parameters of the TDA6120, the thermal resistance of the required heatsink for the maximum temperatures allowed can be calculated with equations (3) and (4).

$$R_{th,heatsink} = \frac{T_j - T_{amb}}{P_{tot}} - R_{th,j-mb} - R_{th,mb-hs} \quad (3)$$

With (3): The maximum junction temperature allowed is 150 °C at 10.4 Watt. This means that the thermal resistance of the heatsink must be smaller than 5.7 K/W.

$$R_{th,heatsink} = \frac{T_{hs} - T_{amb}}{P_{tot}} \quad (4)$$

With (4): The maximum heatsink (board) temperature allowed is 105 °C at 10.4 Watt. This means that the thermal resistance of the heatsink must be smaller than 3.8 K/W.

The required heatsink area can be derived from the heatsink design nomogram published by PHILIPS COMPONENTS⁷. For a thermal resistance of 3.8 K/W the required heatsink area is 100 cm². With this heatsink the calculated (equation (3)) maximum junction temperature at 10.4 Watt is < 130 °C ($T_{amb} = 65$ °C).

On the pc board described in this report, a standard heatsink (shown in Fig. 22) is used. This heatsink has an $R_{th,hs}$ of 5.6 K/W natural convection (3.75 K/W in continuous air flow). With this heatsink the ΔT under maximum dissipation (10.4 Watt) is 59 °C. The heatsink temperature will rise to 124 °C and the junction temperature to 150 °C.

With the above results in mind it is recommended that, to prevent derating of pcb material and for safety, the thermal protection circuit as shown in Fig. 3 is used to limit the heatsink temperature to a maximum of 100 °C (a ΔT of 35 °C).

To verify the calculated dissipation and temperature behaviour of the video board, the board has been tested in a HR monitor.

* The maximum allowed temperature for **FR-2** printed circuit board material is 100°C, for **FR-3** pcb material 105°C and for **CEM-1** pcb material 120°C. The maximum allowed temperature for soldering joints is 100°C.

22 MHz Video Amplifier for Large Jumbo Picture Tubes

Application Note ETV/AN95008

Measuring the Power Dissipation of the TDA6120 in practise.

All temperature measurements are made with a Minolta infrared temperature sensor at the RED output stage. The RED output stage is physically positioned above the BLUE output stage and thus suffers from a higher ambient temperature. The red output stage is driven to a 90 Volt output swing at 20 MHz (40 MHz pixel frequency; this is the worst case condition that could be reached).

Note: This worst case power dissipation is measured with the thermal protection circuit disabled but the beam current limiting circuit enabled.

- 1 The ambient temperature (T_{amb}) in the (open) set is 26 °C
- 2 The voltage over resistor R110 is 5.4 Volt, the high voltage supply $V_{idd} = 189.5$ Volt.

$$I_{dd} = \frac{5.4 V}{R110} = 54 \text{ mA} \quad P_{high} = V_{idd} * I_{dd} = 10.2 \text{ Watt} \quad (5)$$

- 3 The voltage over resistor R106 is 1.2 Volt, the low voltage supply $V_{cc} = 12.1$ Volt.

$$I_{cc} = \frac{1.2 V}{R106} = 36.4 \text{ mA} \quad P_{low} = V_{cc} * I_{cc} = 0.4 \text{ Watt} \quad (6)$$

- 4 The temperature of the heatsink of the RED channel is 75 °C.

With these practical values for the supply voltages and currents, the true dissipation is calculated to be $P_{tot} = 10.6$ Watt (compare calculated total dissipation at 22 MHz/100 V ≈ 10.4 Watt).

With the above practical measurements, and the measured ambient temperature $T_{amb} = 26$ °C, and a realistic thermal heatsink resistance $R_{th,hs} = 5.6$ K/W, a theoretical value for ΔT can be calculated with equation (7).

$$\Delta T = T_j - T_{amb} = R_{th,hs} * P_{tot} = 58^\circ \text{ C} \quad (7)$$

In practise a value of $\Delta T = 49$ °C is found.

Conclusion:

In any case the PC-board and the TDA6120 junction temperature must be protected by a thermal protection circuit as given in Fig. 3. With the resistor values indicated in Fig. 3 the ΔT of the heatsink is limited to 27 °C (by limiting the voltage over R•10 to 1.2 Volt). In practise the maximum heatsink requirements are lower than those calculated under worst case conditions so that a smaller heatsink can be used.

By adapting the resistor values the thermal protection circuit can be optimised for other heatsink sizes.

Warning: The used heatsink must have an $R_{th,hs} < 11.4$ K/W because of the quiescent $P_{stat} = 3.5$ Watt.

22 MHz Video Amplifier for Large Jumbo Picture Tubes

Application Note ETV/AN95008

2.3 The Interface between TDA4780 and TDA6120.

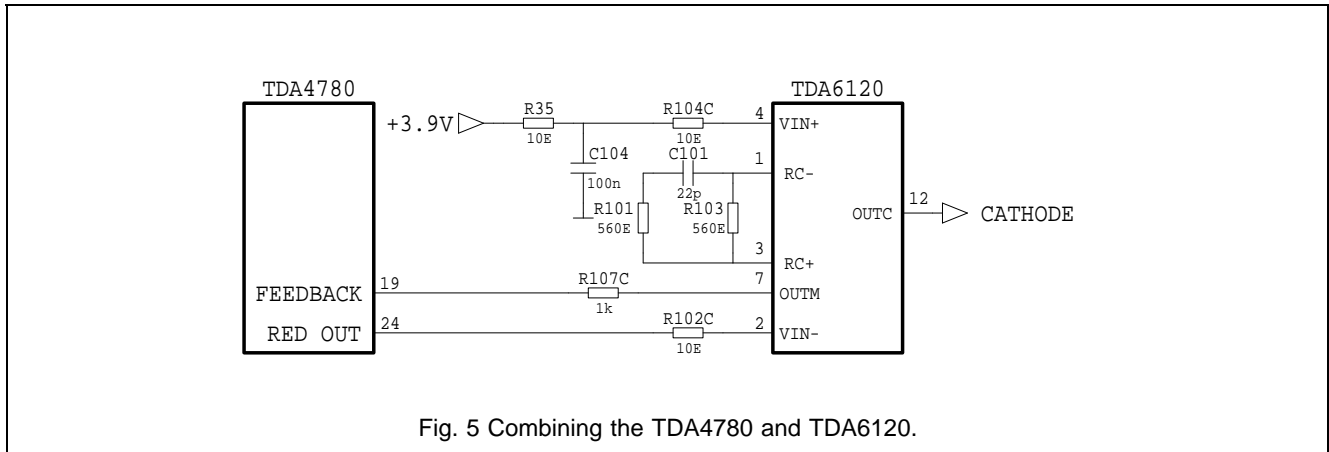

Fig. 5 Combining the TDA4780 and TDA6120.

The output signals (R, G, B) of the TDA4780 are between $2 V_{pp}$ (typical output voltage difference Black to White level) and a maximum of $3.3 V_{pp}$. This means that to achieve the maximum output amplitude of $150 V_{pp}$ at the cathode, the amplification ratio of $R \cdot 13$ over $R \cdot 03/2$ must be > 45 . This is done by choosing the value for $R \cdot 03 = 560 \Omega$. The value for $R \cdot 13 = 18 \text{ k}\Omega$ is fixed (for this see paragraph 2.2).

3. POWER SUPPLY.

The supply voltages for the video amplifier board are (see also Fig. 6);

- 200 Volt (100 mA) for the TDA6120 (high voltage) video drive with $R71 = 10 \Omega$ in series.
- 13 Volt (100 mA) for the TDA6120 (low voltage) through $R73 = 3 \times 68 \Omega //$ and D73, a 13 Volt zener.
- 8 Volt (100 mA) for the TDA4780 supply through $R5 = 22 \Omega$ and a (IC1 = $\mu A7808$) voltage regulator.
- 3.9 Volt (14 mA) for the TDA6120 (reference level) through $R9 = 820 \Omega$ and D9, a 3.9 Volt zener.

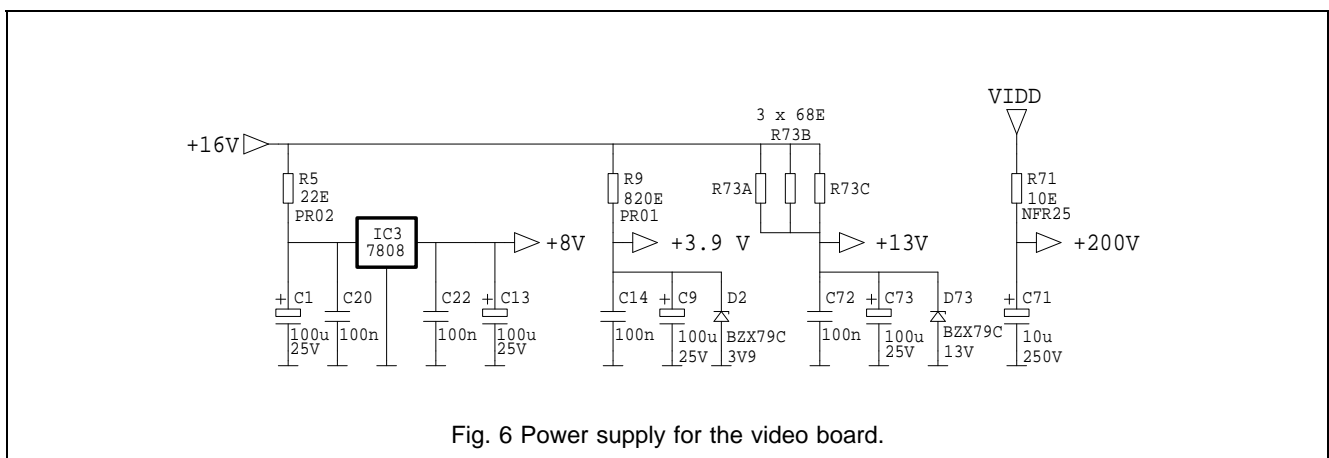

Fig. 6 Power supply for the video board.

Note: Before connecting the video board make sure that both capacitors on the 200 Volt supply, on the SMPS board and C71, are discharged. When this is not done this can result in a fused (R71) resistor.

22 MHz Video Amplifier for Large Jumbo Picture Tubes

Application Note ETV/AN95008

3.1 Performance of the Video Amplifier Board.

The video amplifier board was tested in a HR monitor. It is connected to an RGB signal generator with high performance 75 Ω coaxial cable, terminated at the video board with 75 Ω to ground. The four oscilloscope traces are obtained with a Tektronic 500 MHz Digital Oscilloscope.

The input signal rise and fall times, measured on the video board with a 10:1 probe, are shown in Fig. 7. For a link to the f_{-3dB} bandwidth see equation (1), appendix 2; specification of video modes.

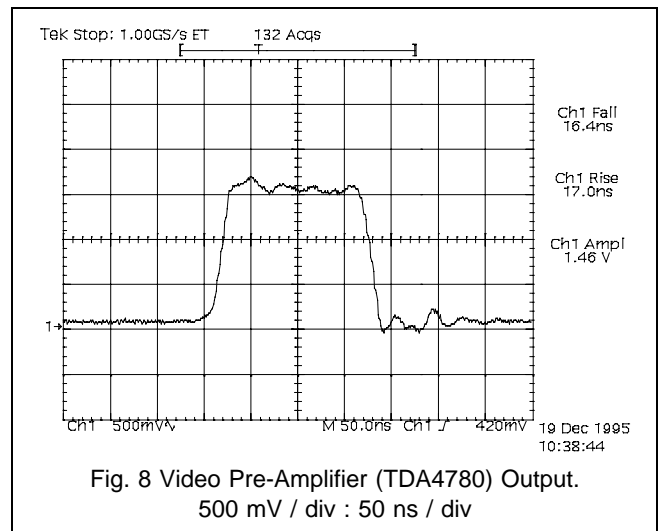
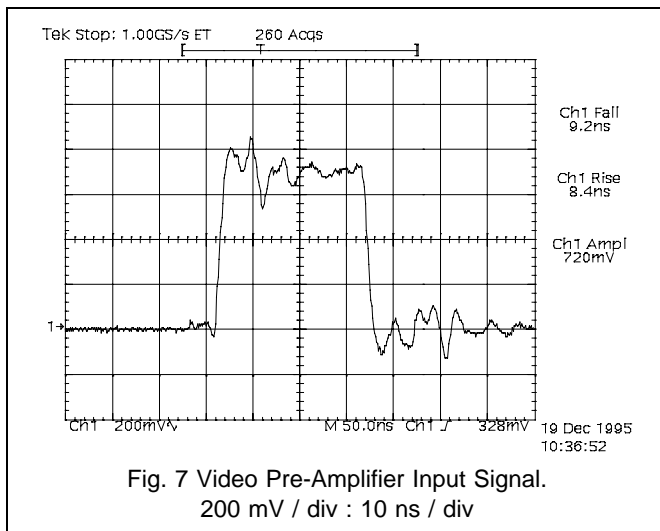

The output signal of the TDA4780 to the TDA6120 is shown in Fig. 8. The contrast is set for a cathode output voltage swing (black to white) of 60 Volt (Fig. 9) and 125 Volt (Fig. 10), the waveform is measured using a 2.4 pF 100:1 Philips probe. The output of the TDA6120 is measured on the cathode.

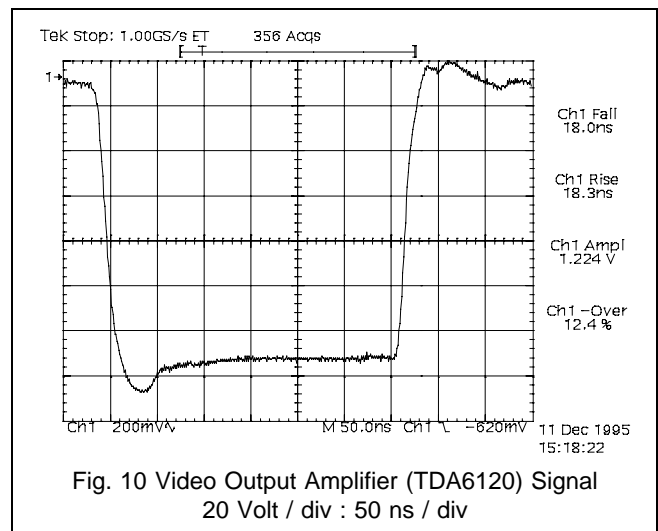
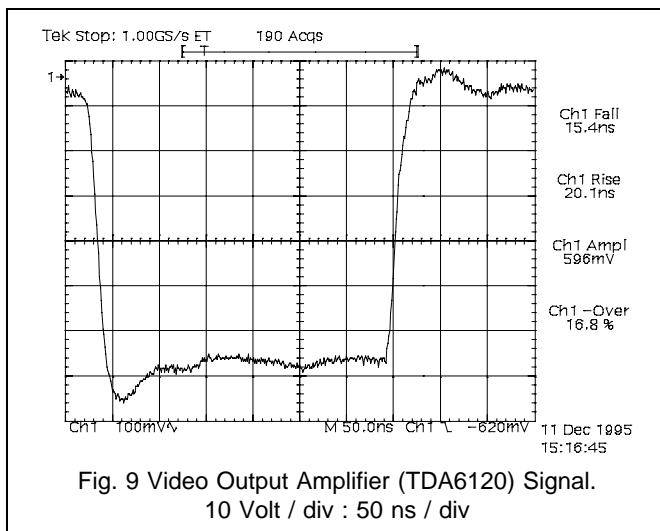

The difference in rise and fall times is caused by the speed-up networks. With the output voltage swing of 60 Volt, the 10% to 90% fall time (black to white) is 15.4 ns and the rise time is 20.1 ns, with an overshoot of 17 %. As can be deduced from table 2 appendix 2, these results relate to an excellent performance at 22 MHz pixel frequency down to an acceptable performance at 45 MHz pixel frequency.

4. VIDEO AMPLIFIER BOARD SCHEMATIC DIAGRAMS, LAYOUT AND PARTS LISTS.

4.1 Picture Tube Drive.

For **Electro Magnetic Compatibility** reasons, part of the connections to the picture tube go via this picture tube board. Since these lines include V_{g1} , heater voltage and Aquadag connection it will be clear that precautions must be taken to prevent flash over energy from destroying the sensitive electronics.

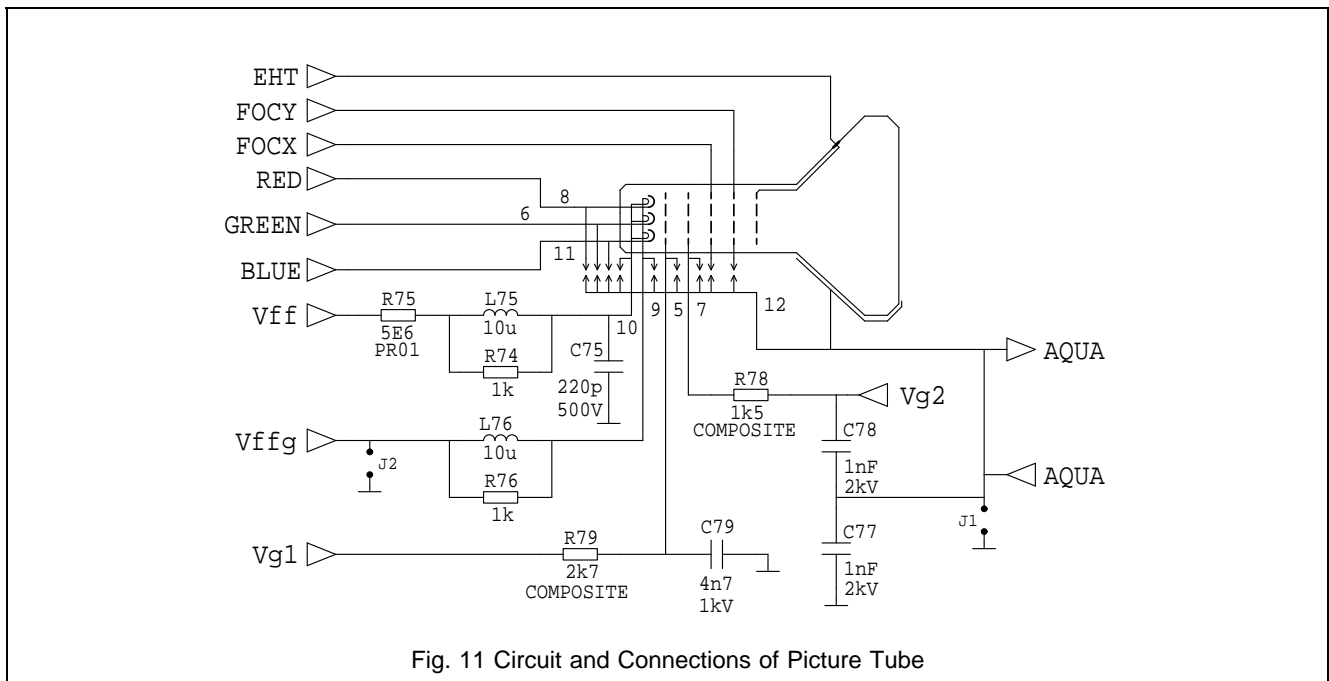

Fig. 11 Circuit and Connections of Picture Tube

The value of heater resistor R75 lies between 2Ω and 6Ω (dependent on the tube type; for example, a value of 5Ω is found for the 29" SF picture tube). It is recommended to optimise resistor R75 for the optimal heater voltage of $6.15 V_{rms}$.

4.2 Video Amplifier Board Design.

The final design of the video amplifier board is made on double sided PC-board. Special efforts have been made to keep all current loops (carrying high di/dt signals) as small as possible. This is visible in the copper area shown in Fig. 12 and Fig. 14.

On the board there is an option to terminate all grounds (AQUA, GND and Vffg) to the same ground (GND) pin 7 of connector 8 by means of the jumpers J1 and J2 next to capacitor C75 and coil L75. With the HR monitor design the placement of both jumpers gave the best results.

22 MHz Video Amplifier for Large Jumbo Picture Tubes

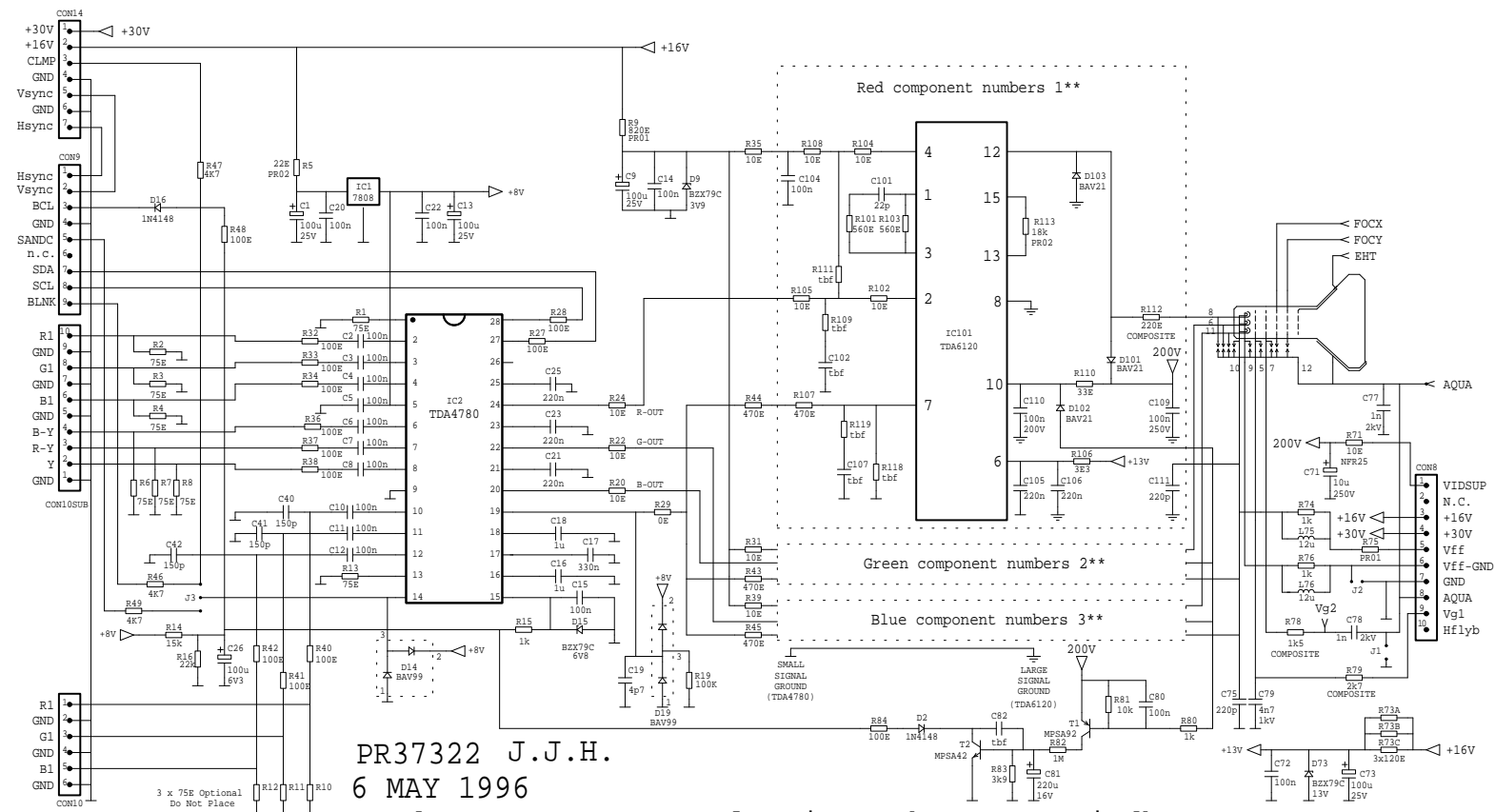

Fig. 13 Video amplifier with TDA4780 and TDA6120 schematic diagram.

22 MHz Video Amplifier for Large Jumbo Picture Tubes

Application Note ETV/AN95008

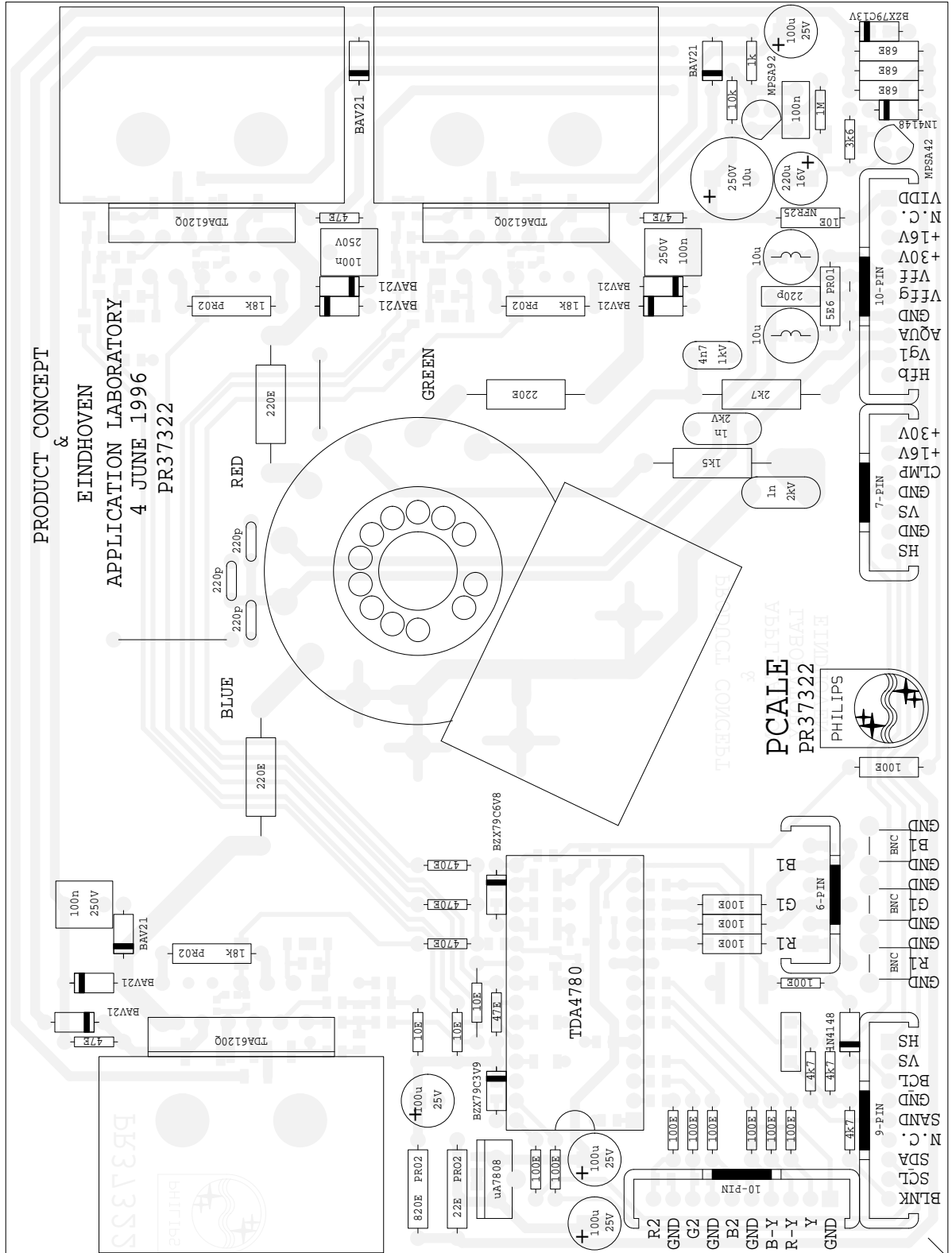

Fig. 15 Video amplifier component placement (values)

22 MHz Video Amplifier for Large Jumbo Picture Tubes

Application Note ETV/AN95008

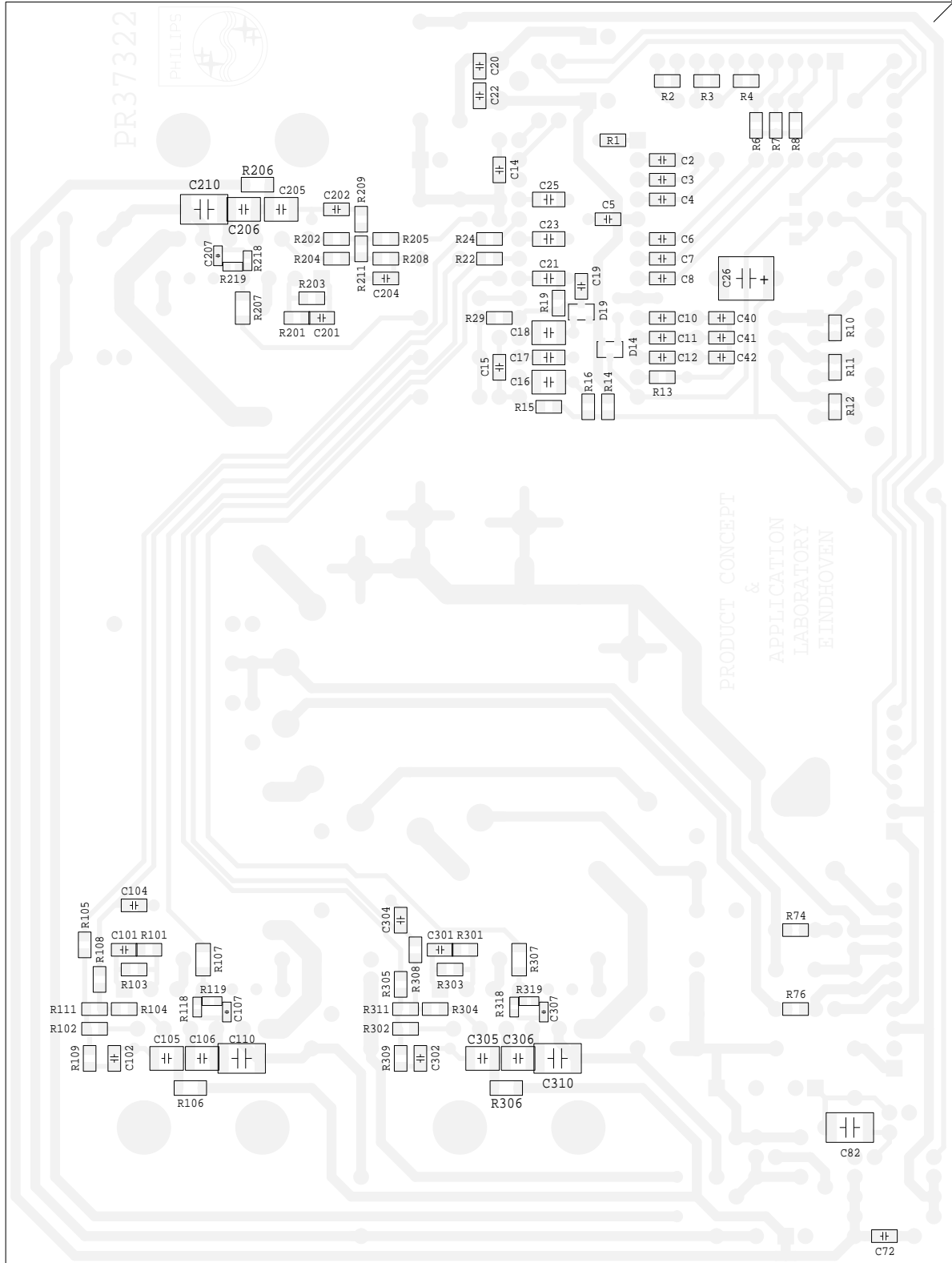

Fig. 16 Video amplifier SMD placement (numbers)

22 MHz Video Amplifier for Large Jumbo Picture Tubes

**Application Note
ETV/AN95008**

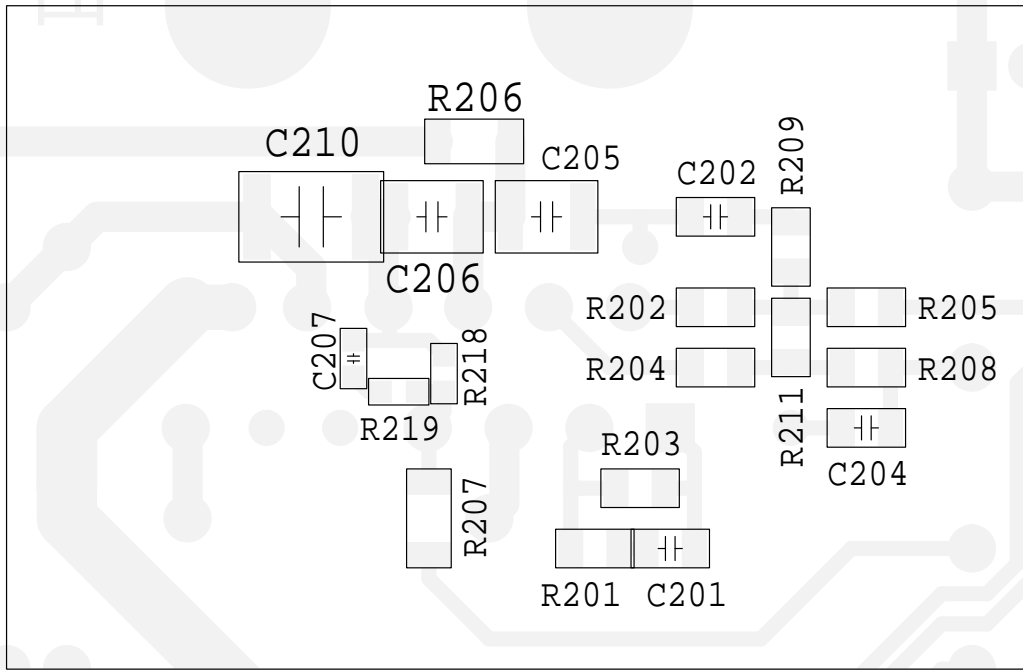

Fig. 20 TDA6120 SMD Placement (Numbers) Enlarged View.

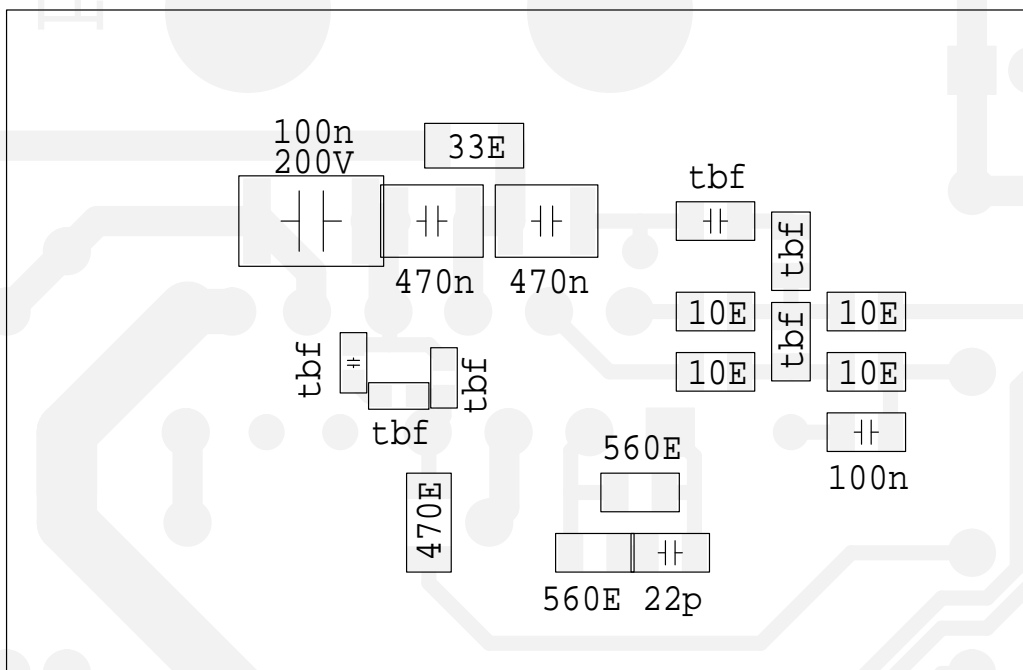

Fig. 21 TDA6120 SMD Placement (Values) Enlarged View.

22 MHz Video Amplifier for Large Jumbo Picture Tubes

Application Note
ETV/AN95008

4.3 Parts List.

22 MHz VIDEO AMPLIFIER FOR LARGE JUMBO PICTURE TUBES PR37322

Diodes

Component	value	type	12 n.c.	Number
D2 D16	1N4148	DO35	9330-839-90153	2
D9	BZX79C3V9	DO35	9331-176-90153	1
D15	BZX79C6V8	DO35	9331-177-50153	1
D14 D19	BAV99	SOT23	9332-153-70212	2
D73	BZX79C13V	DO35	9331-178-30133	1
D101 D102 D103 D201 D202 D203 D301 D302 D303	BAV21	DO35	9331-892-10153	9

Integrated Circuits

Component	value	type	12 n.c.	Number
T1	MPSA92	PNP		1
T2	MPSA42	NPN		1

Integrated Circuits

Component	value	type	12 n.c.	Number
IC1	μ A7808	8 Volt regulator		1
IC2	TDA4780	RGB pre-amplifier		1
IC101 IC201 IC301	TDA6120Q	Video output amplifier		3

Miscellaneous

Component	value	type	12 n.c.	Number
J1 J2	Wire 1E	Wire		2
J3	3-pin jumper			1
J4	Wire 6E	Wire		1
J5	Wire 4E	Wire		1
BNC1 BNC2 BNC3	Coax terminator	2 Legs vertical mount		3
CON8	10-PIN	CON10		1
CON9	9-PIN	CON9		1
CON10B	10-PIN	CON10		1
CON10	6-PIN	CON6		1
CON14	7-PIN	CON7		1
L75 L76	10 μ	COIL		2
SOCKET	DAF-SOCKET	CRT_DAF		1

22 MHz Video Amplifier for Large Jumbo Picture Tubes

Application Note ETV/AN95008

PARTS - LIST 22 MHz VIDEO AMPLIFIER FOR LARGE JUMBO PICTURE TUBES PR37322

Electrolytic Capacitors

Component	value	range	12 n.c.	Number
C1 C9 C13 C73	100u	25V	2222-037-90047	4
C71	10u	250V	2222-044-63109	1
C81	220u	16V	2222-037-56221	1

Electrolytic Capacitors (SMD)

Component	value	type	12 n.c.	Number
C26	100u	6V3		1

Film Capacitors

Component	value	range	12 n.c.	Number
C83	100n	63V	2222-370-??104	1
C109 C209 C309	100n	250V	2222-370-35104	3

Ceramic Capacitors

Component	value	range	12 n.c.	Number
C75 C111 C211 C311	220p	500V	2222-655-03221	4
C77 C78	1n	2kV		2
C79	4n7	1kV		1

Ceramic Capacitors (SMD)

Component	value	type	12 n.c.	Number
C2 C3 C4 C5 C6 C7 C8 C10 C11 C12 C15 C15 C20 C22 C72 C104 C204 C304	100n	C0805	2222-910-16649	19
C14 C72	100n	C1206	2222-591-16641	2
C16 C18	1u	C1210	2222-882-16663	2
C17	330n	C1206	2222-591-16647	1
C19	4p7	C0805	2222-861-12478	1
C21 C23 C25	220n	C1206	2222-591-16645	3
C82	tbf	C1812	2222-??-?????	1
C101 C201 C301	22p	C0805	2222-861-12229	3
C102 C202 C302	tbf	C0805	2222-??-?????	3
C105 C106 C205 C206 C305 C306	470n	C1210	2222-882-16558	6
C107 C207 C307	tbf	C0603	2222-??-?????	3
C110 C210 C310	100n 200V	C1812	2222-944-16649	3

22 MHz Video Amplifier for Large Jumbo Picture Tubes

Application Note ETV/AN95008

PARTS - LIST

22 MHz VIDEO AMPLIFIER FOR LARGE JUMBO PICTURE TUBES PR37322

Resistors (SMD)

Component	value	type	12 n.c.	Number
R1 R2 R3 R4 R6 R7 R8 R13	75E	R0805	2322-730-??759	8
R10 R11 R12	do not place (Optional 75E)	R0805	2322-730-??759	3
R14	15k	R0805	2322-730-??153	1
R15 R74 R76	1k	R0805	2322-730-??102	3
R16	22k	R0805	2322-730-??223	1
R19	100k	R0805	2322-730-??104	1
R22 R24 R102 R104 R105 R108 R202 R204 R205 R208 R302 R304 R305 R308	10E	R0805	2322-730-??109	18
R29	0E	R0805	2322-730-??009	1
R101 R103 R201 R203 R301 R303	560E	R0805	2322-730-??561	6
R106 R206 R306	33E	R1206	2322-710-??339	3
R107 R207 R307	470E	R1206	2322-710-??471	3
R109 R111 R118 R119 R209 R211 R218 R219 R309 R311 R318 R319	tbk	R0603	2322-730-?????	16

Resistors (Standard, Non-Flammable and Power)

Component	value	type	12 n.c.	Number
R5	22E	PRO2	2322-1??-??229	1
R9	820E	PR01	2322-193-??821	1
R20 R31 R35 R39	10E	SFR16	2322-180-??109	4
R27 R28 R48	100E	SFR16	2322-180-??101	3
R32 R33 R34 R36 R37 R38 R40 R41 R42 R84	100E	SFR25	2322-181-??101	10
R43 R44 R45	470E	SFR16	2322-180-??471	3
R46 R47 R49	4k7	SFR16	2322-180-??472	3
R71	10E	NFR25	2322-205-??109	1
R73A R73B R73C	68E	SFR25	2322-181-??689	3
R75	5E6	PR01	2322-193-??568	1
R78	1k5	Carbon Composite		1
R79	2k7	Carbon Composite		1
R80	1k	SFR16	2322-180-??102	1
R81	10k	SFR16	2322-180-??103	1
R82	1M	SFR16	2322-180-??105	1
R83	3k9	SFR16	2322-180-??392	1
R110 R210 R310	47E	SFR16	2322-180-??479	2
R112 R212 R312	220E	Carbon Composite		3
R113 R213 R313	18k	PR02	2322-1??-??183	3

4.4 Heatsink used on the Video Amplifier Board.

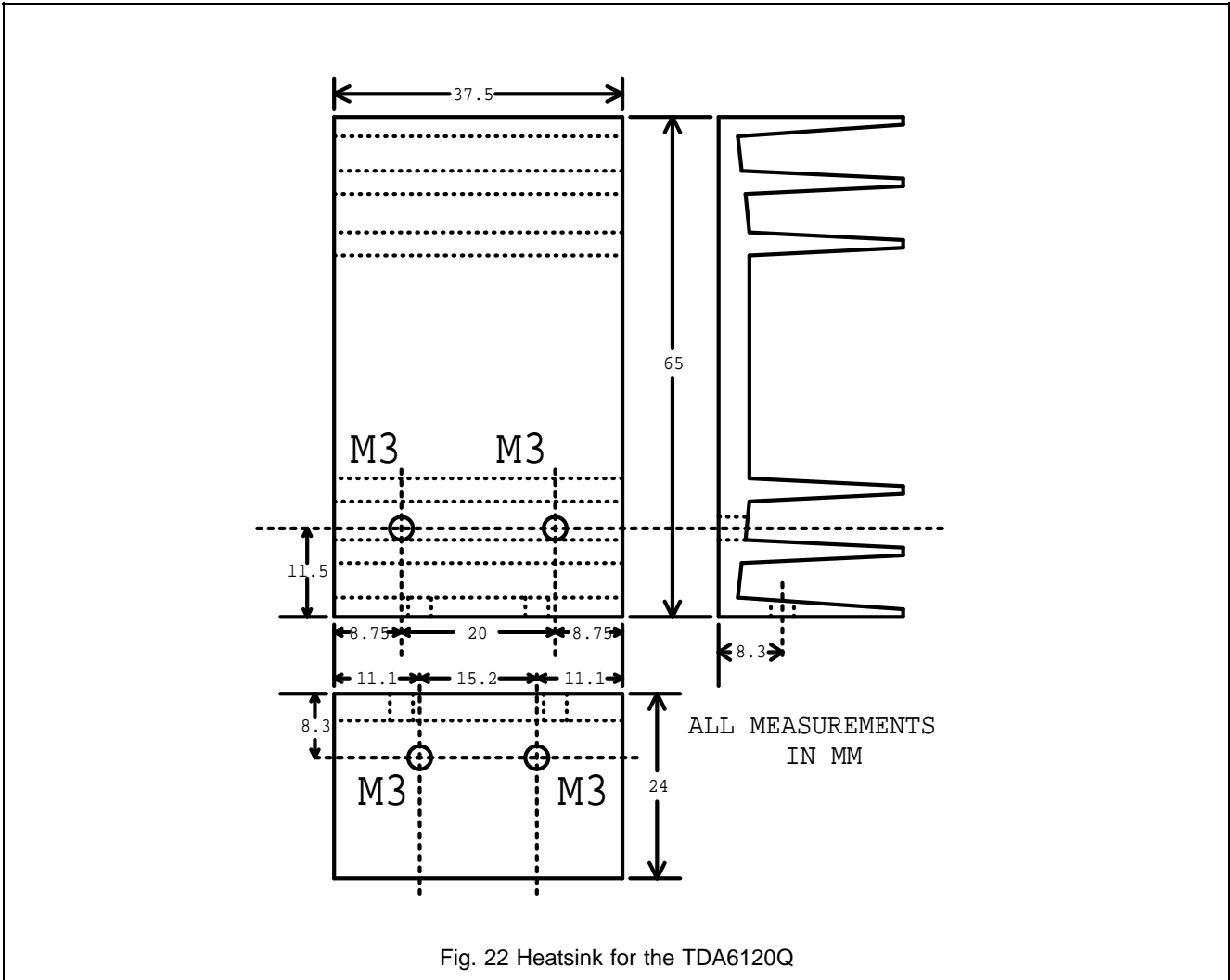

The heatsink shown in Fig. 22 is a standard heatsink that can be found with most manufacturers. The drilled holes are to be taped with M3.

22 MHz Video Amplifier for Large Jumbo Picture Tubes

Application Note
ETV/AN95008

5. ACKNOWLEDGMENT.

This project was done with help of the following people:

F. v.d. Zanden	Mounting PC boards and demo board assembly
R. v.d. Linden	Mounting PC boards and demo board assembly
D. Teuling	Consultancy
J. Hulshof	Consultancy

6. REFERENCES.

1. TDA4780 RGB video processor with automatic cut-off control
IC02b 1995 and gamma adjust
2. TDA6120 Video Output Amplifier
DATASHEET
3. TDA4882 Advanced monitor video controller
IC02b 1995
4. ETV/AN95007 Video Amplifier for HR Monitor with TDA4882 and TDA6120
by J.J. Hekker
5. ETV/AN93015 Scan Velocity Modulation for HDTV Monitors
by H.J.C. Büthker
6. ETV/AN95006 Large Screen Deflection Board
by J.J.M. Hulshof
7. Technical Long-life mounting for l.f. power transistors,
Publication 227 PHILIPS COMPONENTS Technical Publication 227

22 MHz Video Amplifier for Large Jumbo Picture Tubes

Application Note ETV/AN95008

APPENDIX 1 SPECIFICATION AND PINNING OF THE INTEGRATED CIRCUITS.

The TDA4780.

The TDA4780 is a monolithic integrated circuit with a luminance and a colour difference interface for video processing in TV receivers. Its primary function is to process the luminance and colour difference signals. The required inputs are:

- luminance and negative colour difference signals.
- 2- or 3-level sandcastle pulse for internal timing pulse generation.
- I²C-bus data and clock signals.

TABLE 1 Pin Description of the TDA4780 Video Processor.

Pin	Function	Parameters	Pin	Function	Parameters
1	Fast switch 2 input select Y - CD / RGB ₁ select RGB ₂ I ² C control bits FSDIS2,FSON2	0.0 - 0.4 V _{dc} 0.9 - 5.5 V _{dc}	15	Average beam current limiting input start brightness reduction start contrast reduction	2.5 V _{dc} 4.0 V _{dc}
2	RED input 2	0.7 V _{pp}	16	Peak limiting storage capacitor start brightness reduction start contrast reduction	2.5 V _{dc} 4.0 V _{dc}
3	GREEN input 2	0.7 V _{pp}	17	Storage capacitor for leakage current compensation	
4	BLUE input 2	0.7 V _{pp}	18	Peak dark storage capacitor	
5	Supply Voltage V _p Supply Current	8.0 V _{dc} ± 10% 100 - 120 mA	19	Cut-off measurement input maximum charge/discharge current	400 µA
6	Colour Difference -(B-Y) 75% colour bar	1.33 V _{pp}	20	BLUE output black to white maximum output current / amplitude	1.7 - 2.3 V _{pp} nominal 5 mA typical / 3.3 Volt
7	Colour Difference -(R-Y) 75% colour bar	1.05 V _{pp}	21	Blue cut-off storage capacitor	
8	Luminance input Y I ² C control bit YHI = 0 I ² C control bit YHI = 1	0.45 V _{pp} 1.43 V _{pp}	22	GREEN output black to white maximum output current / amplitude	1.7 - 2.3 V _{pp} nominal 5 mA typical / 3.3 Volt
9	Ground	Ground	23	Green cut-off storage capacitor	
10	RED input 1	0.7 V _{pp}	24	BLUE output black to white maximum output current / amplitude	1.7 - 2.3 V _{pp} nominal 5 mA typical / 3.3 Volt
11	GREEN input 1	0.7 V _{pp}	25	Blue cut-off storage capacitor	
12	BLUE input 1	0.7 V _{pp}	26	Y-output/hue adjust output YEXH = 1 Hue (DAC 03) set > 28 _{HEX} YEXH = 0 min - max output voltage	0.85 - 1.15 V _{pp} 0.05 - 5.50 V
13	Fast switch 1 input select Y - CD select RGB ₁ I ² C control bits FSDIS1,FSON1	0.0 - 0.4 V _{dc} 0.9 - 5.5 V _{dc}	27	I ² C bus serial data input/acknowledge output	-0.1 - V _p Volt

**22 MHz Video Amplifier for
Large Jumbo Picture Tubes**

**Application Note
ETV/AN95008**

14	Sandcastle pulse input Horizontal and vertical blanking Horizontal pulses	2.0 - 3.0 V _{dc} 4.0 - 4.9 V _{dc}	28	I ² C bus serial clock input	-0.1 - V _p Volt
----	---	--	----	---	----------------------------

22 MHz Video Amplifier for Large Jumbo Picture Tubes

Application Note ETV/AN95008

Two sets of RGB colour signals can also be inserted. The TDA4780 has I²C bus control of all parameters and functions with automatic cut-off control of the picture tube cathode currents. It provides RGB output signals for the video output stages. In clamped output mode it can also be used as an RGB source. The TDA4780 offers two separate RGB video input channels at a (-3dB) bandwidth of 22 MHz.

The TDA6120.

The TDA6120QQ is a single 30MHz/120Vpp monolithic video output amplifier in a DBS13P (Dil Bended Sil 13 pins Power) package SOT141RDG using high-voltage DMOS technology, and is intended to drive the cathodes of a CRT in High Definition TV's or monitors. The TDA6120 is a new video output amplifier IC with a small signal (60 Volt swing) bandwidth of 60 MHz and a large signal (125 Volt swing) bandwidth of 30 MHz.

TABLE 2 Pin Description of the TDA6120Q Video Output Amplifier (Preliminary data).

Pin	Function	Description	typical	min	max	unit
1	RC-	inverting input pre-emphasis network		0	V_{cc}	V
2	VIN-	inverting voltage input	5	0	V_{cc}	V
3	RC+	non-inverting input pre-emphasis network		0	V_{cc}	V
4	VIN+	non-inverting voltage input		0	V_{cc}	V
5	IIN	feedback current input		0	$2V_{be}$	V
6	V_{cc}	low supply voltage	12	0	24	V
7	OUTM	cathode current measurement output				
8	Ground	power ground & heatsink				
9	n.c.					
10	V_{idd}	high supply voltage	200	0	280	V
11	n.c.					
12	OUTC	cathode output		10	$V_{idd}-10$	V
13	OUT	feedback current output ($R_{fb} = 20\text{ k}\Omega$)		0	10	mA

22 MHz Video Amplifier for Large Jumbo Picture Tubes

Application Note ETV/AN95008

APPENDIX 2 SPECIFICATION AND TIMING OF ACCEPTED VIDEO DISPLAY MODES.

With the following formula the desired picture performance (fall time, black to white transition time) can be calculated (with $\alpha = 0.35$). The results are shown in table 3.

$$t_{\text{pixel}} = \frac{1}{f_{\text{pixel}}} ; \quad \text{With: } f_{-3\text{dB}} = p_i * f_{\text{pixel}} \quad \text{then } t_{\text{fall}} = \frac{\alpha * t_{\text{pixel}}}{p_i} \quad (1)$$

TABLE 3 Performance Demands of an Asymmetrical Video Amplifier.

Resolution ; Pixel Frequency / Video Response					Excellent ($p_i = 1$)	Medium ($p_i = 0.75$)	Acceptabl e ($p_i = 0.5$)
Mode	Pixels (Hor x Vert)	Vertical Frequency (Hz)*	Horizontal Frequency (kHz)	Pixel Frequency (MHz)	t_{fall} (ns)	t_{fall} (ns)	t_{fall} (ns)
VGA	640 x 480	60	31.5	25	14.00	18.62	28.00
VGA (16:9)**	853 x 480	60	31.5	34	10.29	13.73	20.59
VGA	640 x 480	90	48	40	8.75	11.67	17.50
VGA (16:9)	853 x 480	90	48	54	6.48	8.64	12.96
VGA	640 x 480	120	64	55	6.36	8.47	12.73
VGA (16:9)	853 x 480	120	64	74	4.73	6.31	9.46
SVGA	800 x 600	56	35.4	36	9.72	12.96	19.44
SVGA (16:9)	1067 x 600	56	35.4	48	7.29	9.72	14.58
SVGA	800 x 600	72	48	50	7.00	9.33	14.00
SVGA (16:9)	1067 x 600	72	48	67	5.22	6.96	10.45
SVGA	800 x 600	100	64	69	5.07	6.76	10.14
SVGA (16:9)	1067 x 600	100	64	92	3.80	5.07	7.61
XGA	1024 x 768	87 (i)	35.5	46	7.61	10.14	15.22
XGA (16:9)	1365 x 768	87 (i)	35.5	61	5.74	7.64	11.48
XGA	1024 x 768	60	48	64	5.47	7.29	10.94
XGA (16:9)	1365 x 768	60	48	85	4.12	5.49	8.24
XGA	1024 x 768	80	64	88	3.98	5.30	7.95
XGA (16:9)	1365 x 768	80	64	118	2.97	3.95	5.93
HVGA	1152 x 864	70	64	99	3.54	4.71	7.07
HVGA(16:9)	1536 x 864	70	64	132	2.65	3.54	5.30

* When (i) then interlaced mode, all others non-interlaced

** 16:9 means square pixels on a 16:9 aspect ratio picture tube.

**22 MHz Video Amplifier for
Large Jumbo Picture Tubes**

**Application Note
ETV/AN95008**

WIDE*	1848 x 1040	60 (i)	31.5	73	4.79	6.39	9.59
-------	-------------	--------	------	----	------	------	------

* The WIDE mode is a computer graphics version of the HDTV mode. This mode is specifically suitable for the display of for example high resolution Photo CD images.
